

### DESCRIPTION:

The Gas Cartridge Actuator (GCA), P/N 02-4134, provides the necessary pressure to:

- open all Fike's containers utilizing a Fike fast acting rupture disc assembly
- close Fike's fast acting isolation valves.

The GCA consists of a 17-4 PH series stainless steel body containing two (2) sets of bridge wires. This device is designed to operate by electrical input from a Fike system controller, with or without an Analog Release Module (ARM). Operation of the GCA occurs when the electric current is sent through the bridge wires causing an exothermic chemical reaction. This generates the necessary pressure to open the rupture disc and discharge the suppressant agent or pneumatically drive the gate closed on the isolation valves.

Operating temperature range for the GCA is -40° F to +140° F (-40 C to +60 C).

### FEATURES:

- Faster reaction time than conventional systems utilizing detonators.
- Enhanced reliability due to redundant set of bridge wires and hermetic seal.
- Longer service life than detonators.
- Handling, storage, shipping and disposal is easier than a Class "B" explosive.
- Interchangeable with existing detonators.

### HANDLING / STORAGE:

The U.S. Bureau of Alcohol, Tobacco, and Firearms classify the GCA as a special explosive device under 27 CFR 55.32. As such, the GCA is exempt from the licensing and storage requirements contained in the Federal explosives regulations. These devices **do not** have to be stored in a bunker or safe.

### SHELF LIFE:

The GCA is a sealed device utilizing a glass seal and epoxy plug on the wire end and a Mylar seal on the discharge end. This extends the actuator's continuous service and shelf life to 10 years before it requires replacement.

### SHIPPING CLASSIFICATION:

The GCA **will not** detonate any explosive materials or products. It has an U.S. Department of Transportation classification of:

- Class: 1.4
- Compatibility Group: "S"
- Shipping Number: UN0323

This classification allows this device to be shipped on any type of carrier, such as commercial airlines, as well as all forms of land carriers **without** special handling permits and/or licensing.

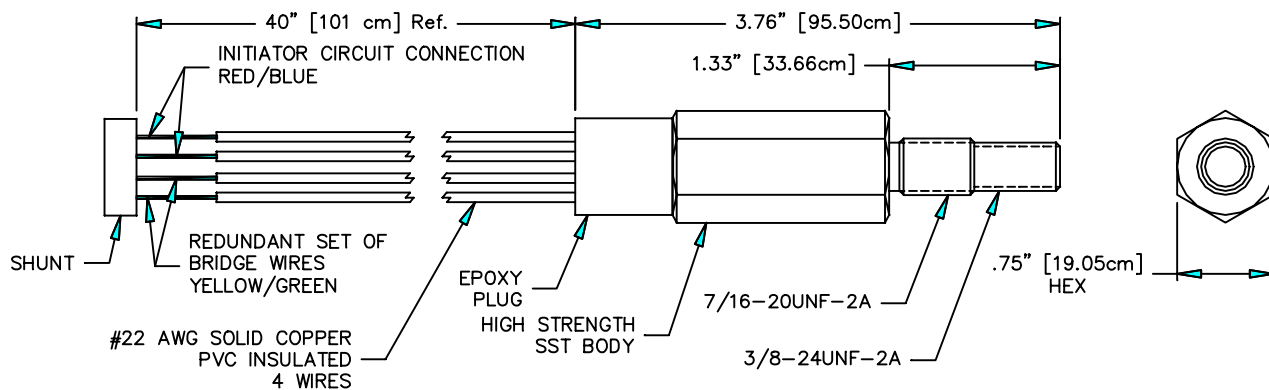

## GAS CARTRIDGE ACTUATOR DETAILS

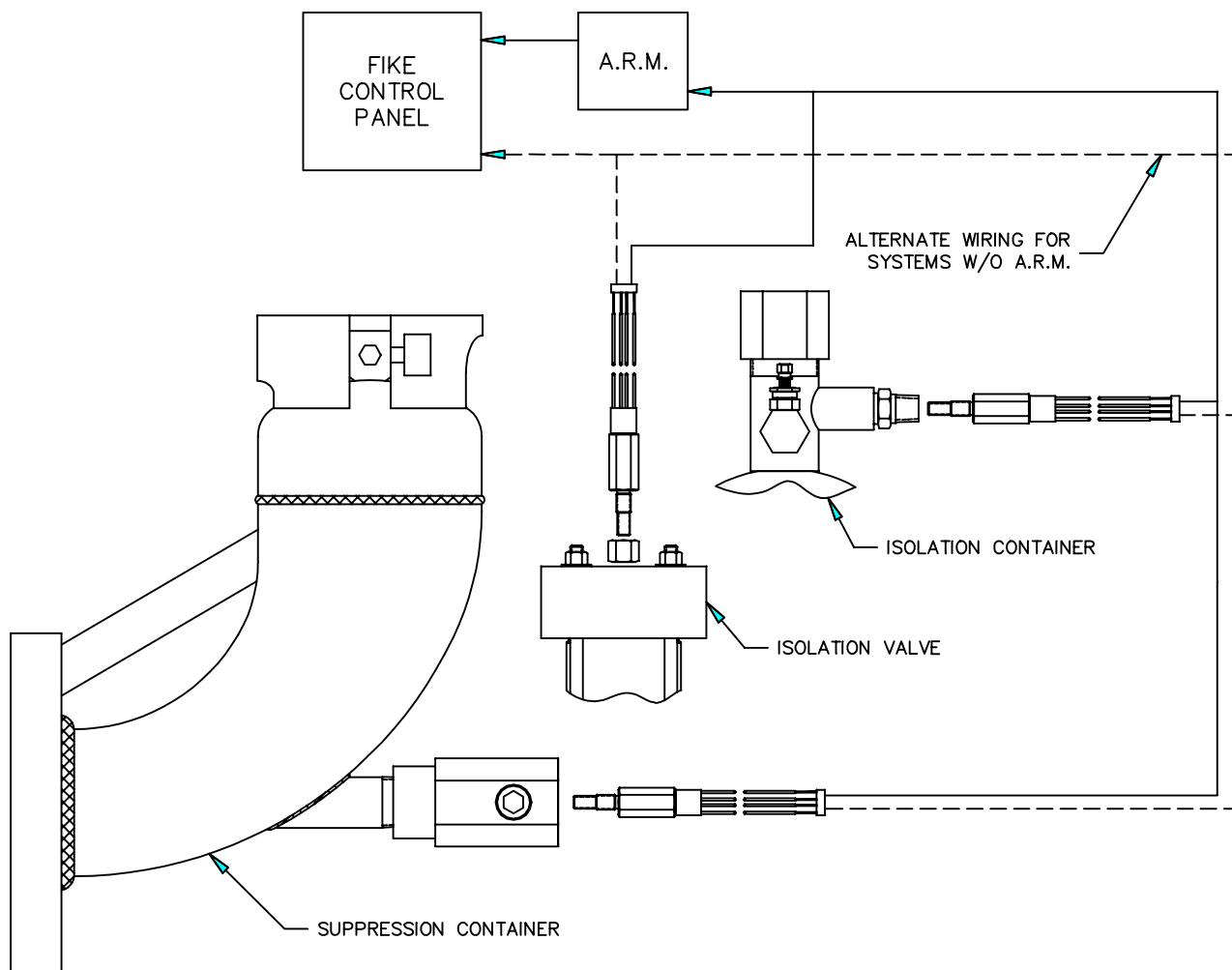

## CONNECTION DIAGRAM