

CV EXPLOSION VENTS

DESCRIPTION

Fike designs simple, reliable explosion protection solutions to meet your safety requirements. Fike’s Composite Vent, or CV, is widely used and sets the industry standard for explosion vents. This flat vent layers stainless steel and FEP or PFA film to create a high performance explosion vent. The CV is an effective solution for static to light pressure cycling and light vacuum conditions.

FEATURES AND BENEFITS

Instantaneous Full Opening	Reduced risk for accidental contamination, elimination of undetected openings
Fail-Safe Design	Certified burst pressure provides full, predictable opening at or below its rated burst pressure even if the vent is damaged
Dynamically Tested	Tested under full-scale explosion conditions not just computer modeling
High Mechanical Integrity	Longer service life
Easy Installation by Plant Personnel	Reduced downtime and maintenance costs
Non-Fragmenting Design	Reduced risk to personnel and equipment
Maintenance Free	Reduced cost of ownership

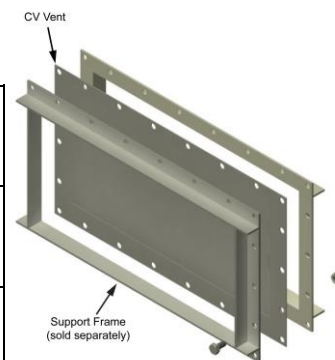

SPECIFICATIONS

Compliance:	NFPA 68, ATEX Certification available (consult factory)
Materials of Construction:	316 SST / FEP or PFA / 316 SST
Maximum Operating Pressure/Vacuum Rating:	75% of the minimum stamped burst pressure for BP ≤ 1.5 psig 60% of the minimum stamped burst pressure for BP > 1.5 psig
Standard Burst Pressure Tolerance:	± 0.25 psig for burst pressures < 1.0 psig ± 0.5 psig for burst pressures 1.0 - 4.0 psig ± 1.0 psig for burst pressures > 4.0 psig
Operating Temperature Range:	-40 to 204°C / -40 to 400°F (FEP) -40 to 260°C / -40 to 500°F (PFA)
Optional Equipment:	Burst indicators / monitoring system; atmospheric insulation; process insulation; weather covers; installation frame; flameless venting; alternative materials, temperature ranges, and tighter tolerances are available



Vent Size		Relief Area		Minimum Burst Pressure		Maximum Burst Pressure	
IN	cm	ft ²	m ²	psig	mbarg	psig	mbarg
9 x 12	23 x 30	0.61	0.057	2.0	138	10.0	690
12 x 12	30 x 30	0.84	.078	2.0	138	8.0	550
12 x 18	30 x 46	1.30	.12	1.5	103	8.0	550
*12 x 24	30 x 61	1.76	.16	1.5	103	8.0	550
18 x 18	46 x 46	2.01	.19	1.0	69	8.0	550
18 x 24	46 x 61	2.72	.25	1.0	69	8.0	550
18 x 30	46 x 76	3.42	.31	1.0	69	8.0	550
24 x 24	61 x 61	3.67	.34	1.0	69	8.0	550
20 x 30	51 x 76	3.83	.36	1	69	8.0	550
*18 x 35	46 x 89	4.01	.37	1.0	69	8.0	550
18 x 36	46 x 91	4.13	.38	1.0	69	8.0	550
24 x 30	61 x 76	4.63	.43	1.0	69	8.0	550
*24 x 36	61 x 91	5.59	.52	.5	35	8.0	550
30 x 30	76 x 76	5.84	.54	.5	35	8.0	550
24 x 44	61 x 112	6.87	.64	.5	35	8.0	550
30 x 36	76 x 91	7.05	.66	.5	35	8.0	550
24 x 48	61 x 122	7.51	.7	.5	35	8.0	550
36 x 36	91 x 91	8.51	.79	.5	35	8.0	550
30 x 44	76 x 112	8.66	.81	.5	35	8.0	550
*36 x 44	91 x 112	10.45	.97	.5	35	8.0	550
44 x 44	112 x 112	12.84	1.19	.5	35	8.0	550
44 x 69	112 x 175	20.31	1.89	.5	35	8.0	550
6 Dia.	15 Dia.	.14	.013	3.0	27	15.0	1030
8 Dia.	20 Dia.	.28	.026	2.5	172	15.0	1030
10 Dia.	25 Dia.	.45	.042	2.0	138	11.0	760
12 Dia.	30 Dia.	.68	.063	2.0	138	10.0	690



14 Dia.	36 Dia.	.95	.088	1.5	103	10.0	690
16 Dia.	41 Dia.	1.27	.12	1.25	86	10.0	690
18 Dia.	46 Dia.	1.62	.15	1.0	69	10.0	690
20 Dia.	51 Dia.	2.02	.19	1.0	69	10.0	690
22 Dia.	56 Dia.	2.46	.23	1.0	69	10.0	690
24 Dia.	61 Dia.	2.95	.27	1.0	69	10.0	690
26 Dia.	66 Dia.	3.48	.32	.8	69	10.0	690
30 Dia.	76 Dia.	4.67	.43	.5	35	10.0	690
36 Dia.	91 Dia.	6.78	.63	.5	35	10.0	690
40 Dia.	102 Dia.	8.40	.78	.5	35	10.0	690
44 Dia.	112 Dia.	10.20	.95	.5	35	10.0	690

* Standard sizes are available with a 1.5 psig nominal burst pressure at 72°F.

- Custom sizes are available
- All dimensions are nominal

INSTALLATION

CV rectangular and circular vents with standard designs are mounted in several lightweight angle frame configurations. CV circular explosion vent designs may be created on special request to accommodate installation between standard flanges in accordance with DIN 3632 PN10 or ANSI B16.5 150. Fike offers frames of multiple configurations and materials. If you prefer to make your own frames, drawings are available for download in the technical support section of www.fike.com.